

This part is made from 4" Schedule 40 PVC pipe

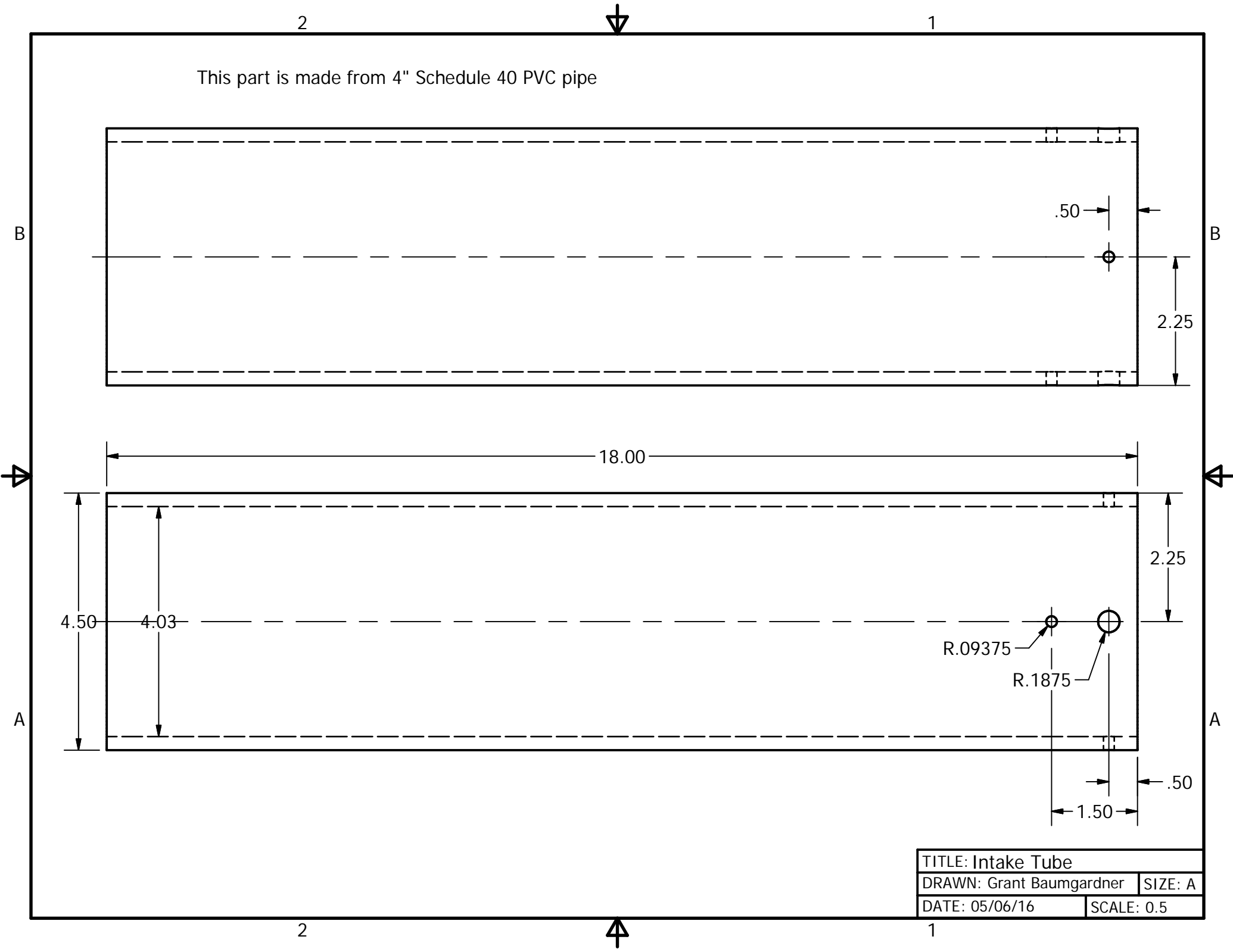

TITLE: Intake Tube	
DRAWN: Grant Baumgardner	SIZE: A
DATE: 05/06/16	SCALE: 0.5

2

1

This part is a 4" x 4" x 2" Schedule 40 PVC Wye with the 2" section cut to the indicated length

B

B

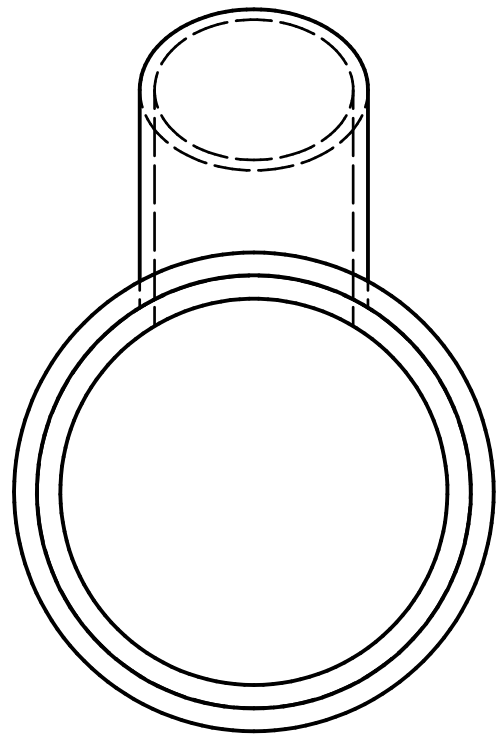
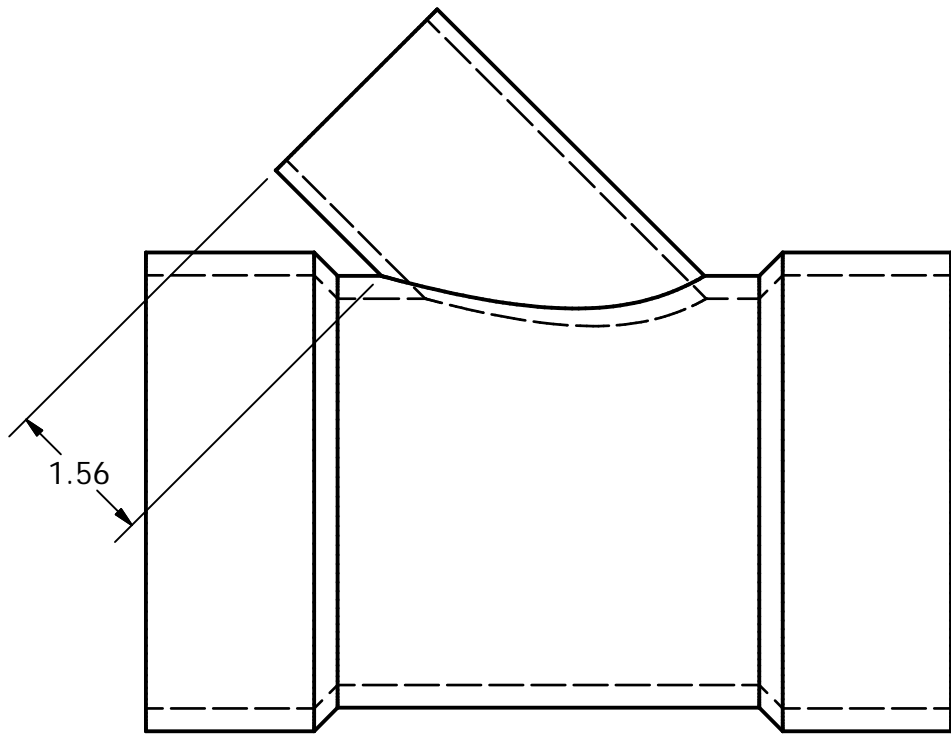

A

A

2

1



TITLE: 4" x 4" x 2" Wye	
DRAWN: Grant Baumgardner	SIZE: A
DATE: 05/06/16	SCALE: 0.5

2" Schedule 40 PVC Pipe

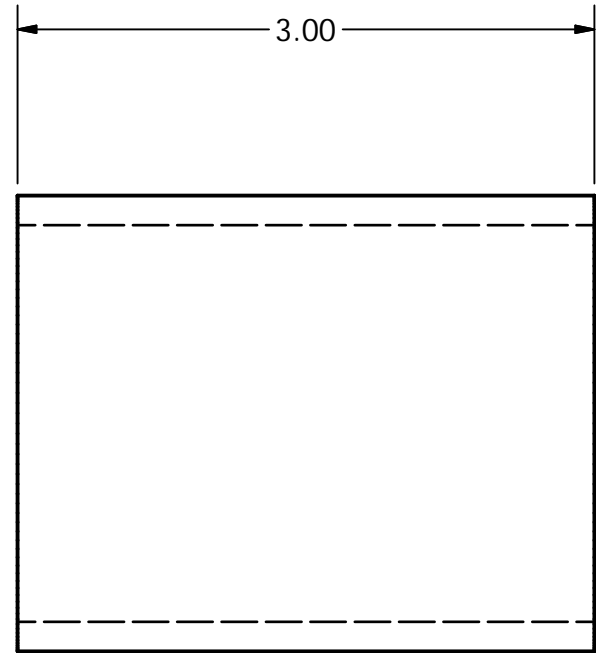
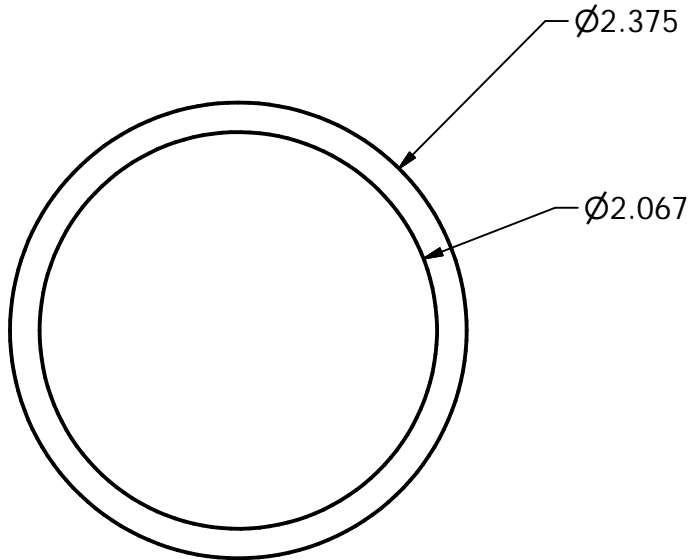

TITLE: Elbow to flexible coupling	
DRAWN: Grant Baumgardner	SIZE: A
DATE: 05/06/16	SCALE: 1 : 1

Made from a Steel Schedule 40 3.5" Pipe

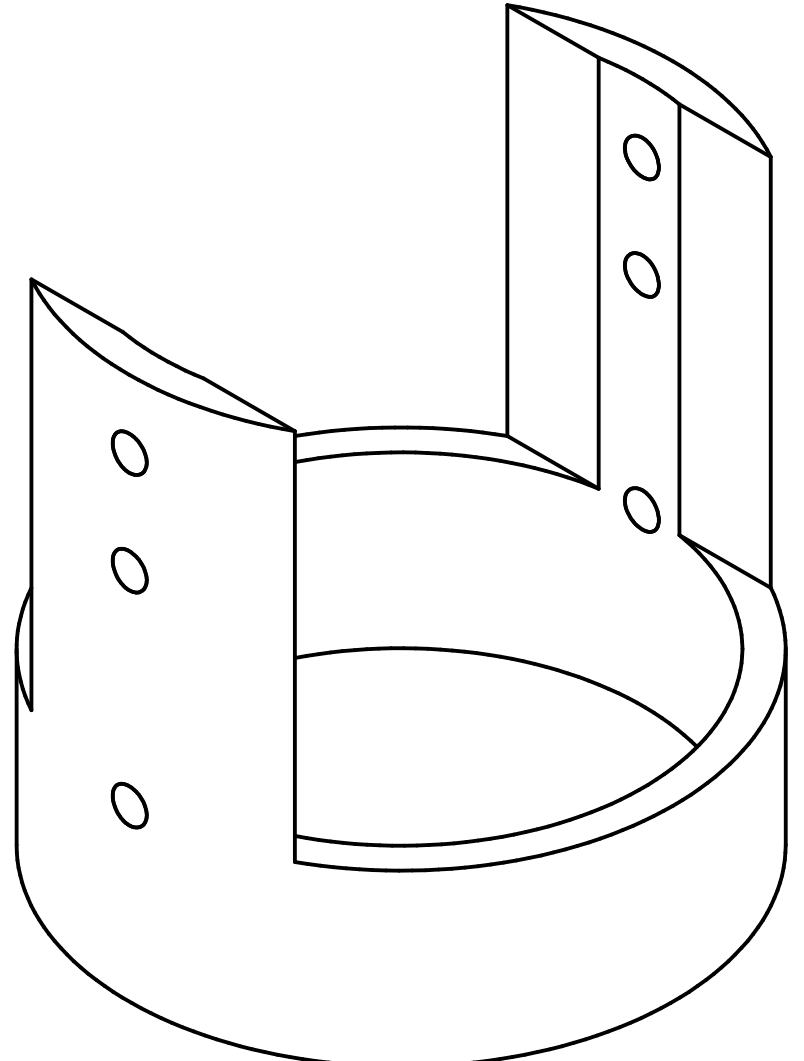
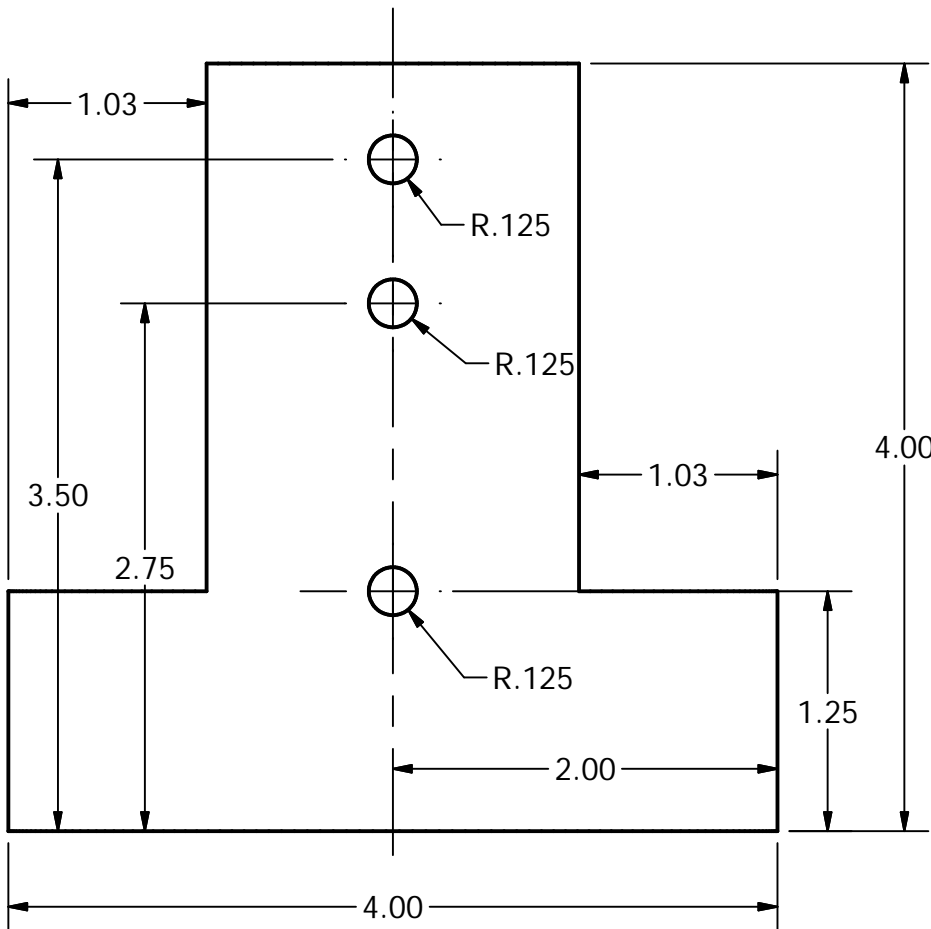

TITLE: Piston	
DRAWN: Grant Baumgardner	SIZE: A
DATE: 05/06/16	SCALE: 1

Cut a 4" Square Door Hinge into this shape to fit inside piston as a valve

Replace hinge pin with 0.25" Rod

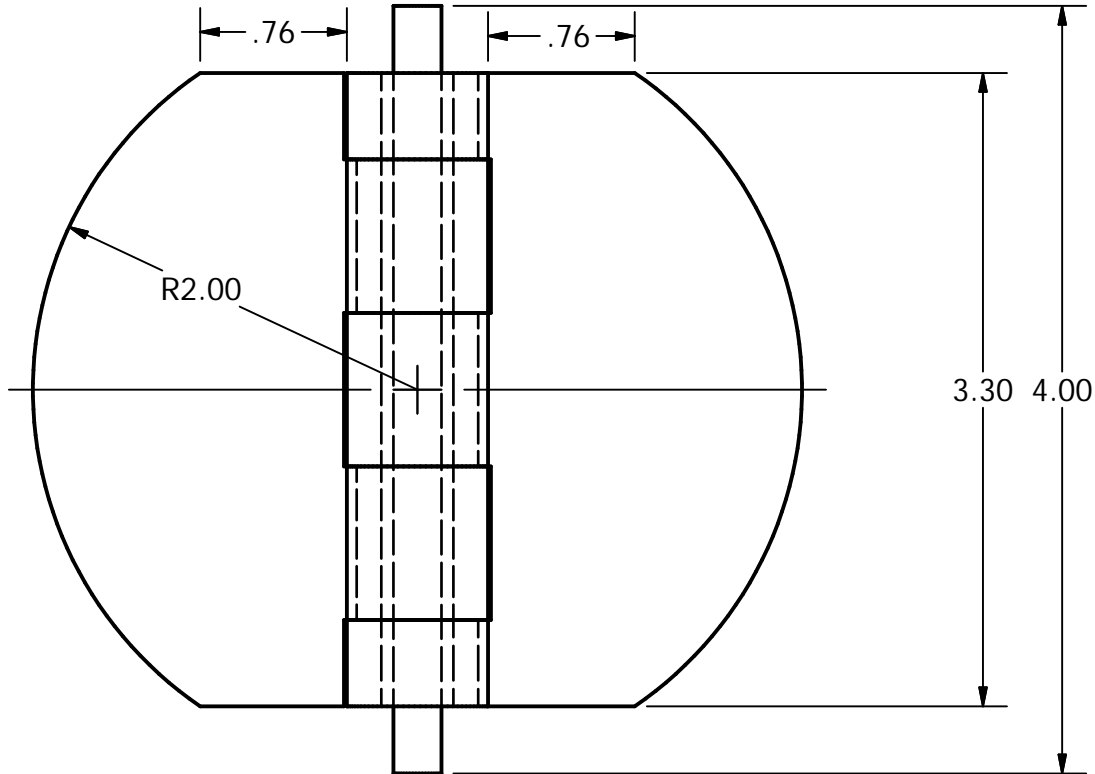
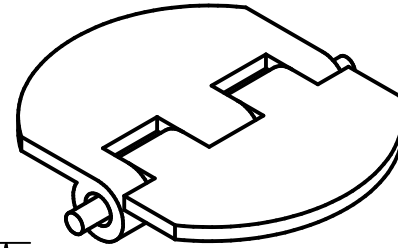
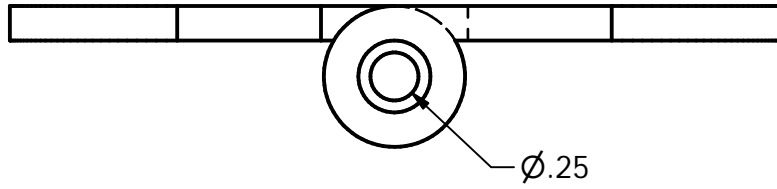

Circle Hinge

TITLE: 16175A37.step	
DRAWN: Grant Baumgardner	SIZE: A
DATE: 05/06/16	SCALE: 1

Cut from 1/16" steel plate

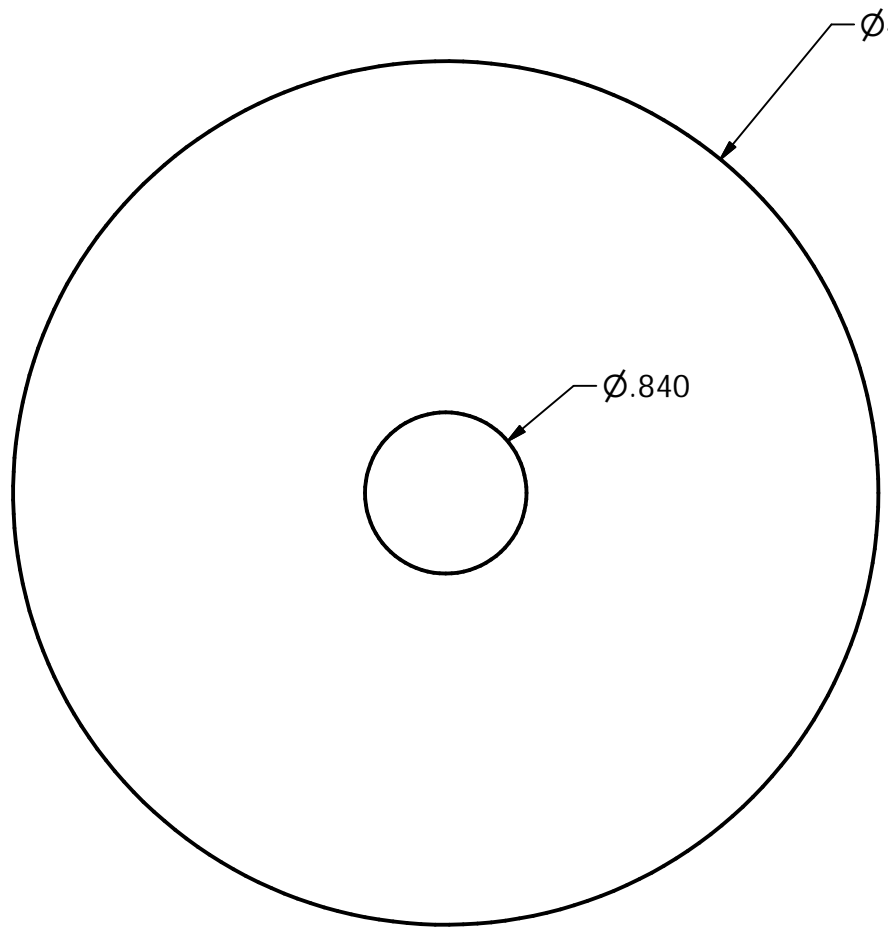

.0625

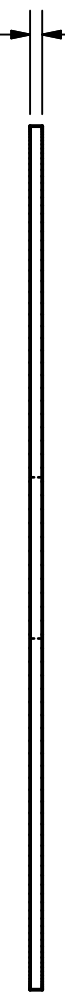

TITLE: Stopper	
DRAWN: Grant Baumgardner	SIZE: A
DATE: 05/06/16	SCALE: 1

Made from a section of 4" Schedule 40 PVC Pipe

Ø4.50

Ø4.03

3.26

TITLE: Wye to Reducer	
DRAWN: Grant Baumgardner	SIZE: A
DATE: 05/06/16	SCALE: 1

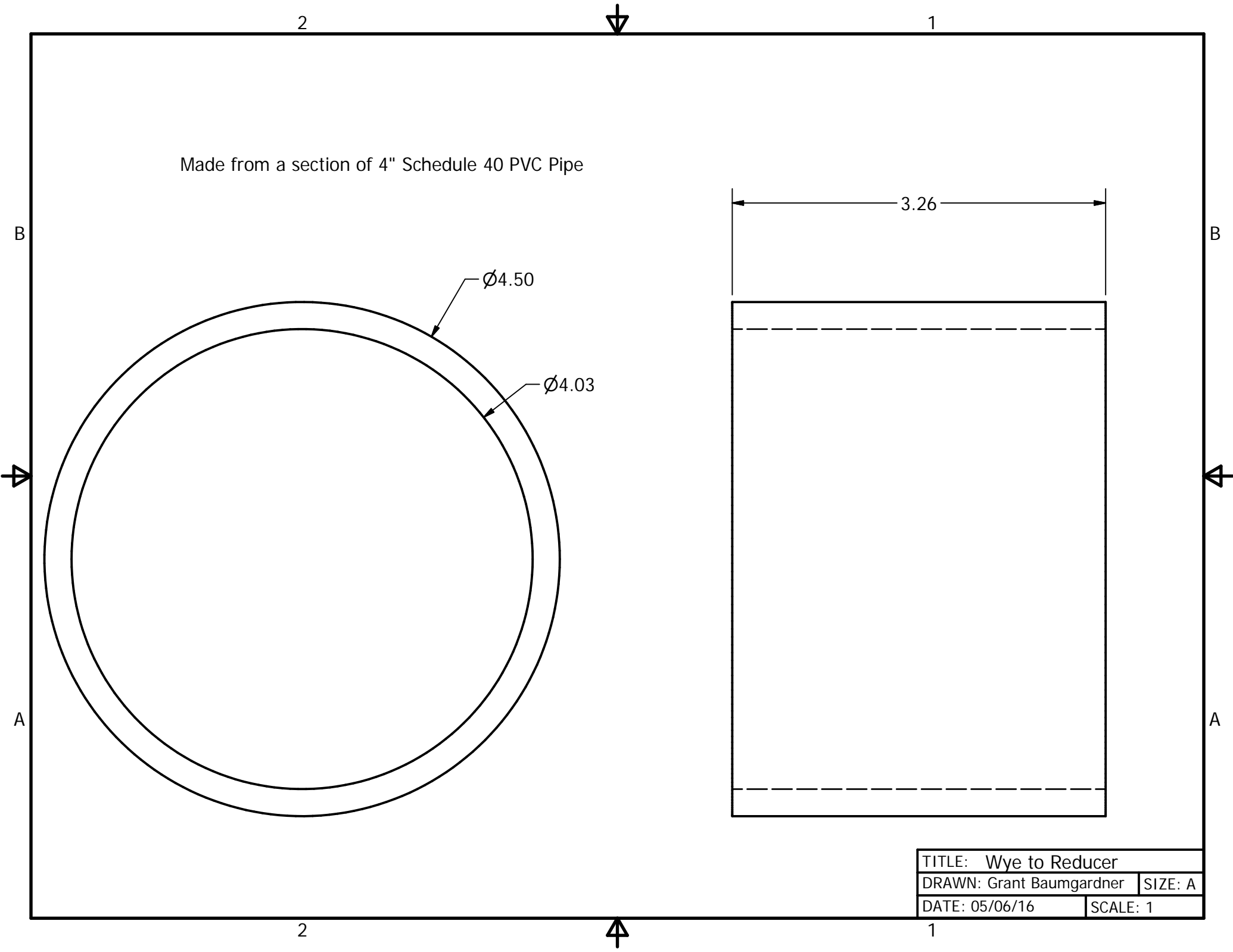

Made from a section of 2" Schedule 40 PVC Pipe

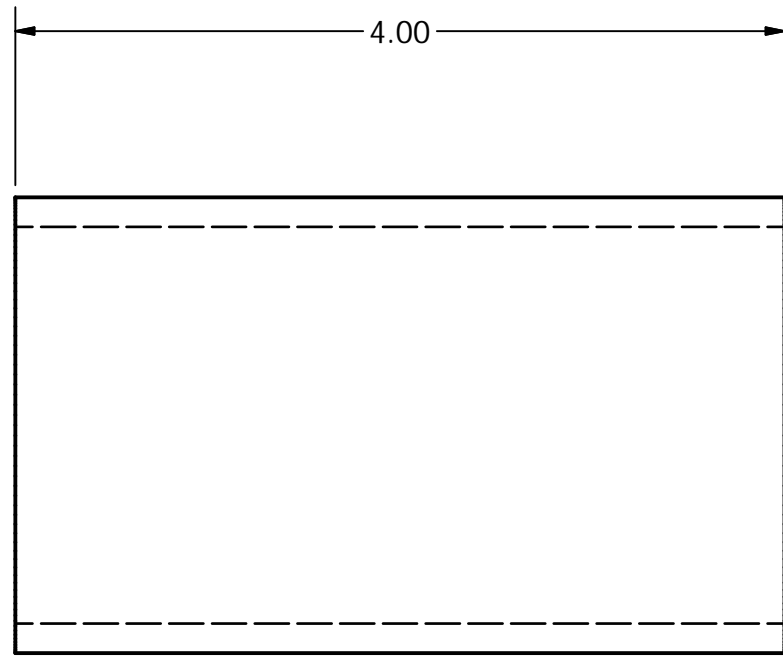
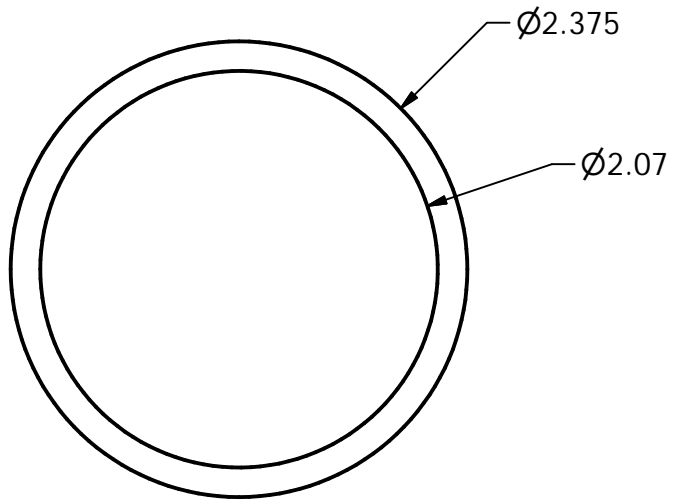

TITLE: Reducer to Coupling	
DRAWN: Grant Baumgardner	SIZE: A
DATE: 05/06/16	SCALE: 1 : 1

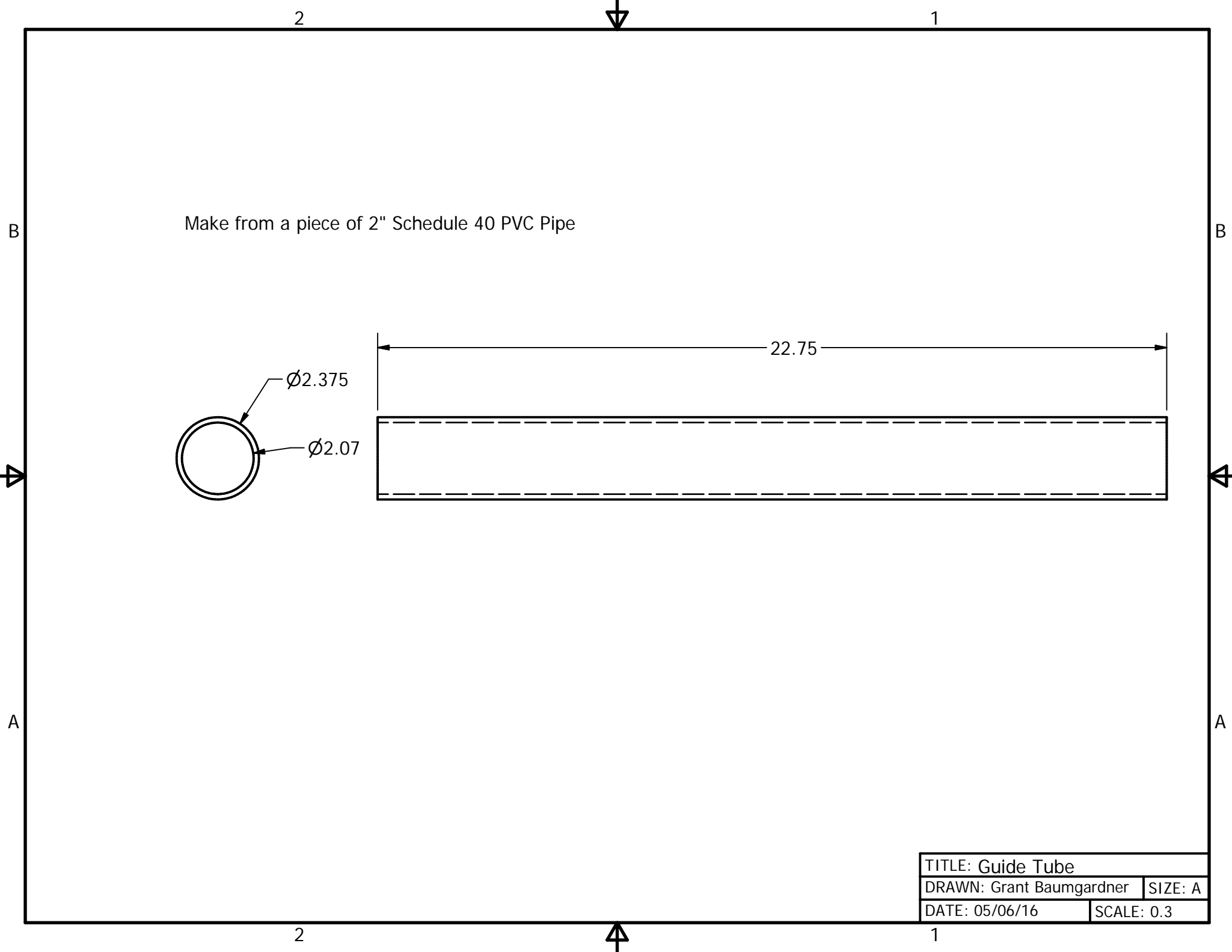

Make from a female 2" PVC threaded cap

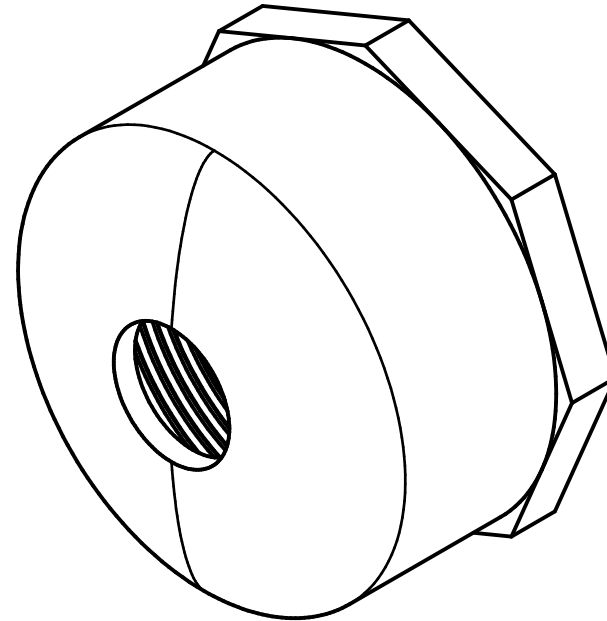
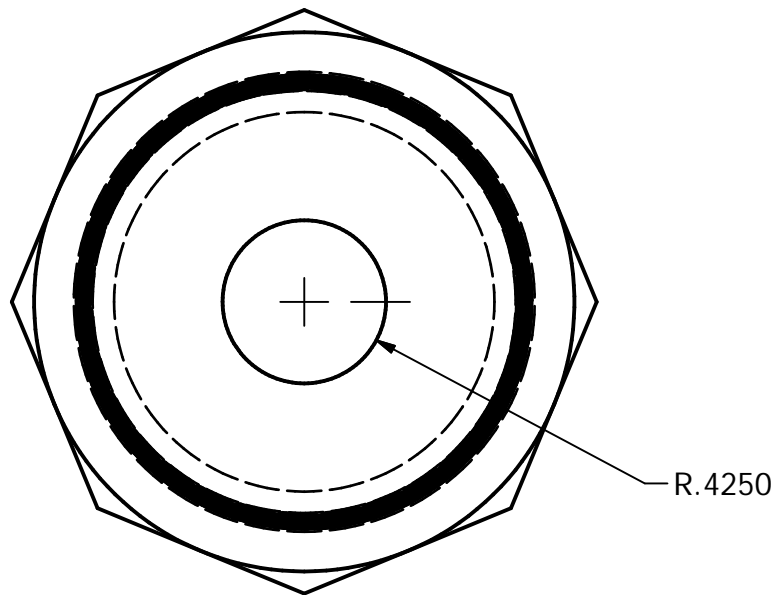

Cap

TITLE: 4880K807.step	
DRAWN: Grant Baumgardner	SIZE: A
DATE: 05/06/16	SCALE: 1

Made from a 1/2" galvanized or black iron water pipe

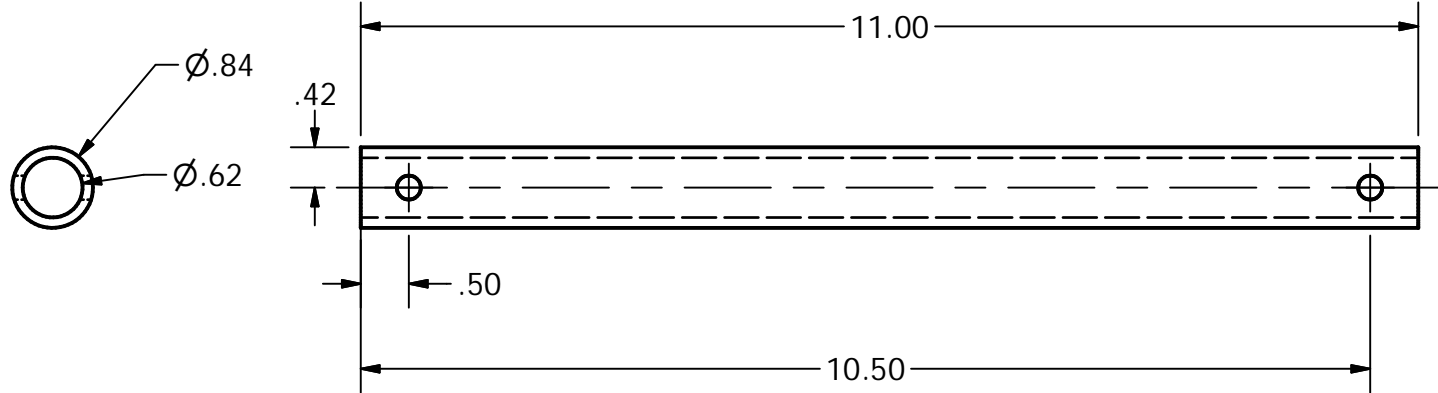

TITLE: Linkage	
DRAWN: Grant Baumgardner	SIZE: A
DATE: 05/06/16	SCALE: 0.5

Made from 1/2" galvanized or black iron water pipe

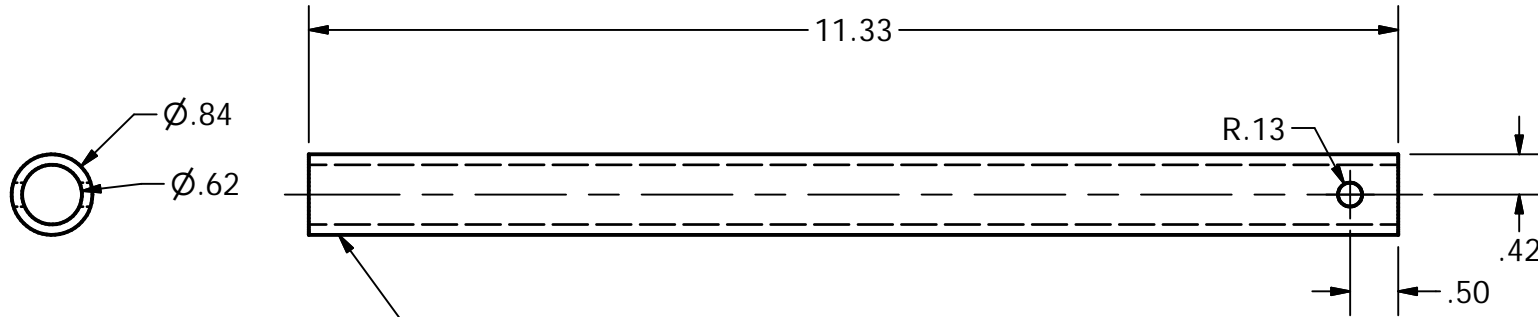

Leave threads on this end for connecting to piston rod

TITLE: Piston Connector	
DRAWN: Grant Baumgardner	SIZE: A
DATE: 05/06/16	SCALE: 0.5

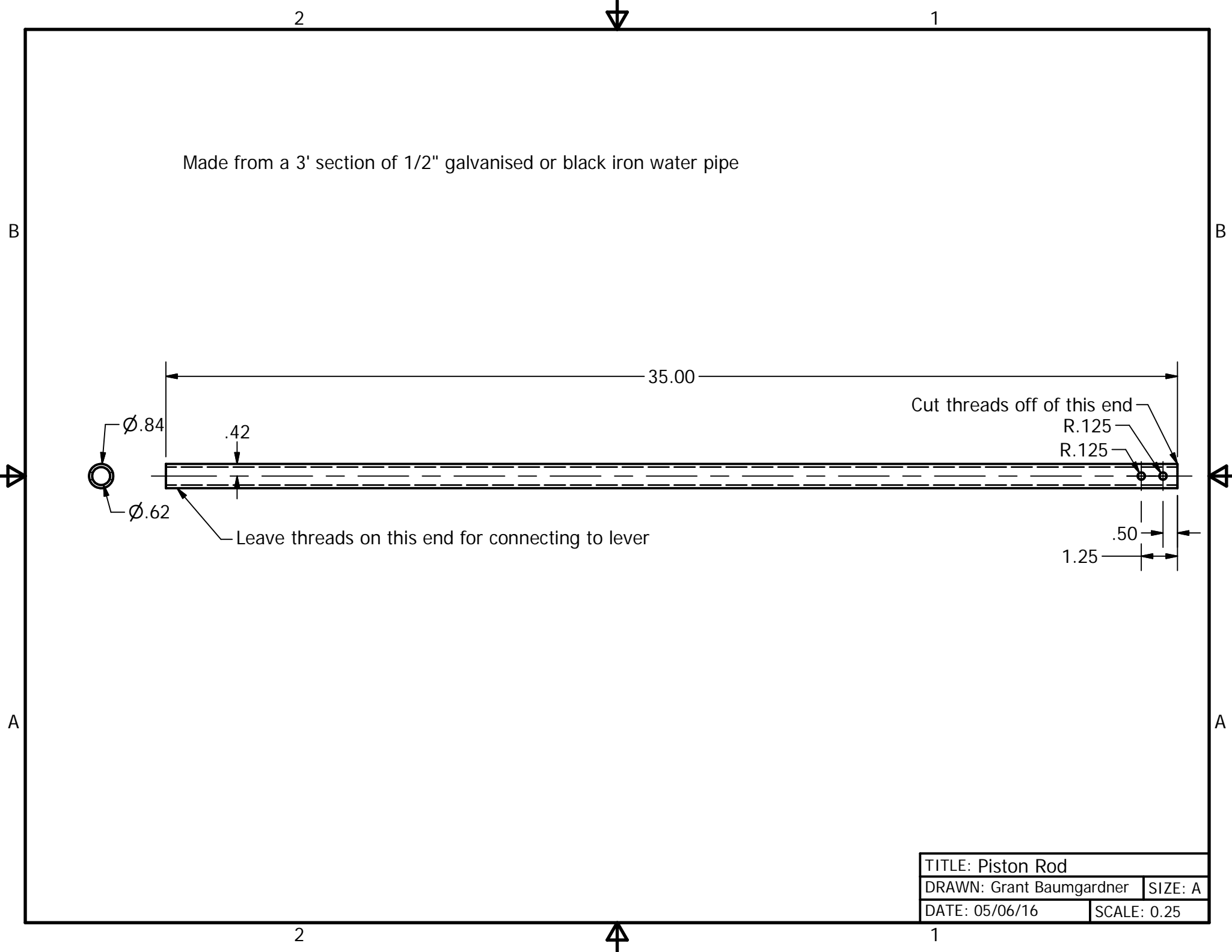

TITLE: Piston Rod	
DRAWN: Grant Baumgardner	SIZE: A
DATE: 05/06/16	SCALE: 0.25

Cut from 1/4" - 20 Threaded Rod

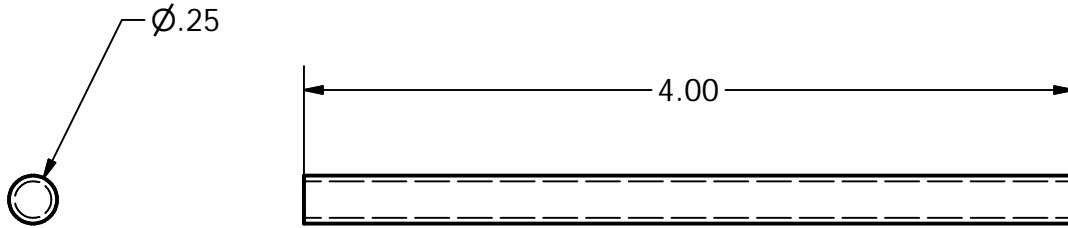

TITLE: Piston to Rod connector	
DRAWN: Grant Baumgardner	SIZE: A
DATE: 05/06/16	SCALE: 1 : 1

2

1

PARTS LIST		
ITEM	PART NUMBER	QTY
1	Linkage	2
2	Cotter Pin	2
3	1/4" x 3.5" Clevis Pin	2
4	1/4" Flat Washer	6
5	Piston Connector	1
6	2" PVC Threaded Cap	1
7	1/2" Steel Pipe Coupling	2
8	Guide Tube Extension	1
9	Threaded Coupling (Male)	1
10	2" PVC connector	1
11	4" to 2" Reducer	1
12	4" PVC (short)	1
13	Stopper	1
14	2" PVC connector (alt)	1
15	2" PVC 45 Degree Elbow	1
16	Piston Rod	1
17	4" x 1/4" - 20 Threaded Rod	2
18	Piston	1
19	Valve	1
20	Intake Tube	1
21	1/4" Nut	4
22	1/4" x 1/2" Bolt	4
23	Bottom Valve	1
24	Spacer Washers	4
25	4" x 4" x 2" wye	1
26	Piston Rod Extension	1

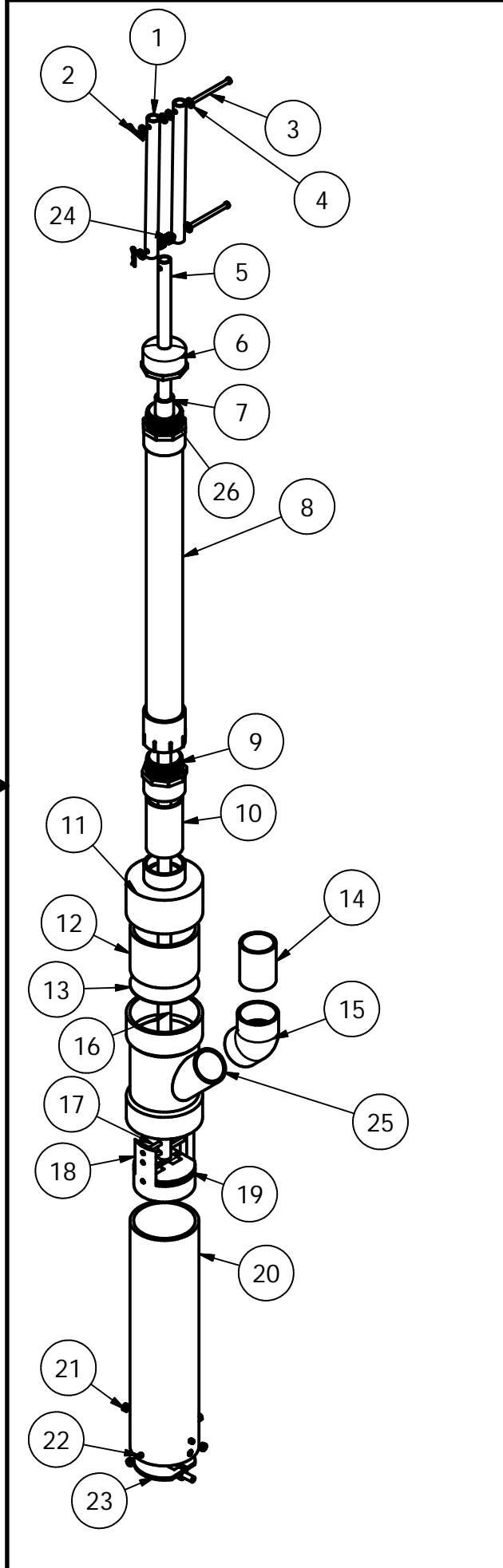

2

1

TITLE: Pump Assembly	
DRAWN: Grant Baumgardner	SIZE: A
DATE: 05/06/16	SCALE: 0.1

